



ENGG 140
TEST #1

8 February. 1996 Room ED 106
TIME- 2:30 P.M. to 3:45 P.M. (1 hr 15 min.)

Do the four questions shown. These questions are taken from Statics Engineering Mechanics. This is the assigned text book. Note : The exam will be marked on methods as well as answers. Make sure that you show all work and that your logic is clear and that you use clear large diagrams. Only your text book and calculator may be used, any other material must be approved before the exam. Assignments and other solved problems will not be permitted. Good luck.

1. Problem # 2.4 page 22.

20%

2. Problem # 2.36 page 33.

20%

3. Problem # 3.23 page 98.

30%

4. Problem # 3.65 page 109.

30%

ENGG 140
MID TERM #1
8 Feb 96

page 2 of 2

2.4 The magnitudes $|F_A| = 60 \text{ N}$ and $|F_B| = 80 \text{ N}$. The angle $\alpha = 45^\circ$. Use trigonometry to determine the magnitude of the force $F = 2F_A - 3F_B$ and the angle between F_B and F .

3.23 A construction worker on the moon (acceleration due to gravity = 5.32 ft/s^2) holds the same crate described in Problem 3.22 in the position shown. What force must she exert on the cable?

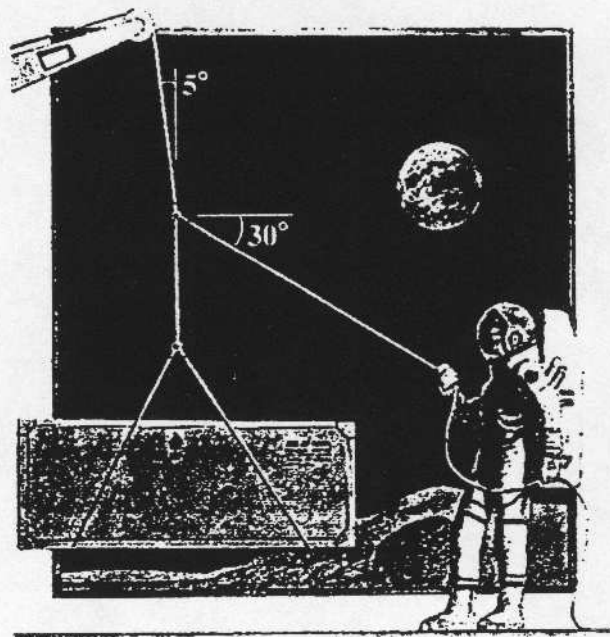

3.65 The 200-kg slider at A is held in place on the smooth vertical bar by the cable AB .

- (a) Determine the tension in the cable.
(b) Determine the force exerted on the slider by the bar.

P3.23

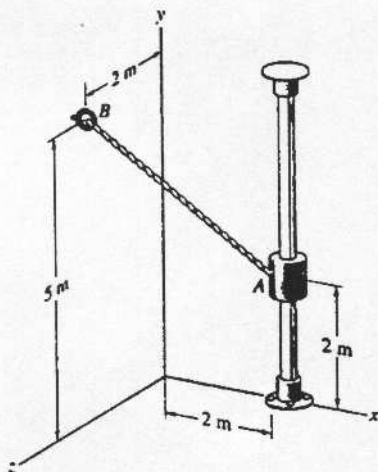

P3.65

2.36 Two cars A and B are on a circular track of 1000 ft radius. The distance between the two cars measured along the track is 2000 ft. What is the position vector from car A to car B in terms of the coordinate system shown?

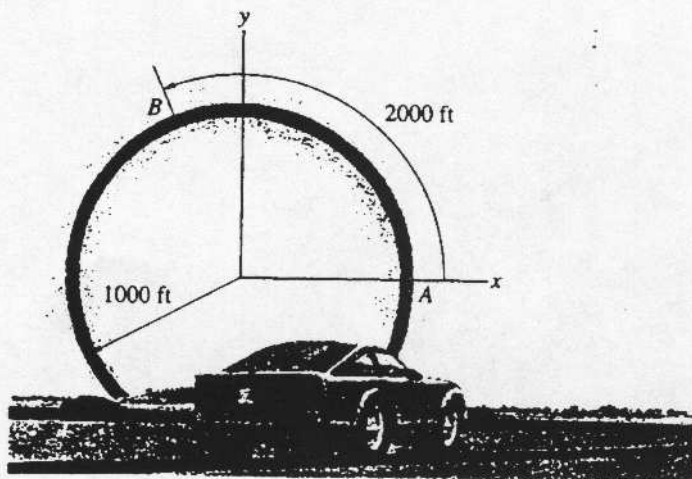

P2.36